

(No Model.)

M. C. JOHNSON.

CUTTING BLADE FOR LATHE TOOLS.

No. 306,257.

Patented Oct. 7, 1884.

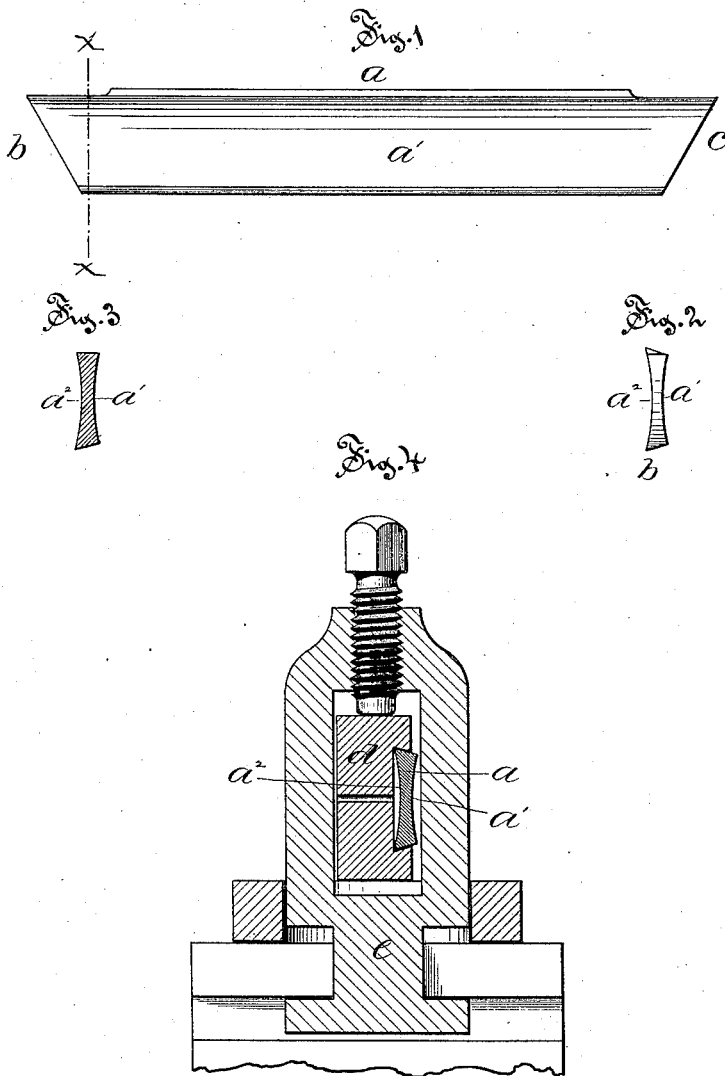

Witnesses

W. M. Forthman
Ed. J. Dimock

Inventor

Moses C. Johnson
By *Simonds & Burdett*
Att'ys.

UNITED STATES PATENT OFFICE.

MOSES C. JOHNSON, OF HARTFORD, CONNECTICUT, ASSIGNOR OF ONE-HALF
TO AMOS WHITNEY, OF SAME PLACE.

CUTTING-BLADE FOR LATHE-TOOLS.

SPECIFICATION forming part of Letters Patent No. 306,257, dated October 7, 1884.

Application filed March 17, 1884. (No model.)

To all whom it may concern:

Be it known that I, MOSES C. JOHNSON, of Hartford, in the county of Hartford and State of Connecticut, have invented certain new and useful Improvements in Cutting-Blades for Lathe-Tools; and I do hereby declare that the following is a full, clear, and exact description thereof, whereby a person skilled in the art can make and use the same, reference being had to the accompanying drawings, and to the letters of reference marked thereon.

Like letters in the figures indicate the same parts.

Figure 1 is a side view of my improved tool. Fig. 2 is an end view of the tool looking from the left. Fig. 3 is a view in cross-section of the blade on plane denoted by line $x x$ of Fig. 1. Fig. 4 is a view in central vertical section of a tool-post and a holder with my improved blade shown in cross-section.

My improvement relates to the class of blades which are especially adapted for use in tool-holders for thread-cutting, cutting-off tools, and the like; and it consists in the peculiar shape of the blade and its parts, whereby greater efficiency is attained than in blades of the prior art.

In the accompanying drawings, the letter a denotes the blade as a whole, made from a flat piece of suitable material, as tool-steel, having suitable cutting-points at one or both ends, as at b and c . The sides a' a'' of the blades are concaved substantially as shown, and the upper and lower edges are beveled to fit a dovetailed socket in the side of a tool-holder, d . Near each end, and for a certain distance

back of the cutting-point, the beveled upper edge of the point is ground flat in order to form the proper cutting-point.

In order to give the necessary clearance to the cutting-point and edge, the blades of a like class with my improvement are tapered in cross-section from the upper to the lower edge, and to hold such a blade with its center in a vertical plane in a holder wedges are used in the holder.

When my improved blade is placed flatwise against a plane surface, a plane passed edge-wise through the center of the blade will be parallel to the supporting-surface, and such a blade has a proper clearance upon both sides of the point. In Fig. 4 this blade is shown as held in a tool-holder, d , secured in an ordinary tool-post, e .

The special advantage of the concave sides of the blade is that it enables the blade to be held in a vertical plane, and they also give the proper clearance in the operation of the cutting-point, and the beveled edges of the blade enable it to be held with a firm grasp in a tool-holder having the lateral socket with undercut grasping-edges, as shown in Fig. 3.

I claim as my invention—

As an improved article of manufacture, a cutting-blade made of a flat piece of tool-steel with concave sides and beveled edges, all substantially as described, and for the purpose set forth.

MOSES C. JOHNSON.

Witnesses:

CHAS. L. BURDETTE,
ED. F. DIMOCK.